

Published Manual Number/ECN: H15 0008/2001074N

- Publishing System: TPAS
- Access date: 2/14/01
- Document ECN's: Exact

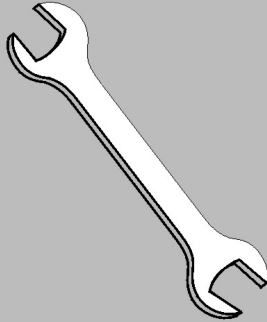

Kit Instruction— K15 0008



Please Read

About the Manual Identifying Information on the Cover

The front cover displays pertinent identifying information for this manual. Most important, are the published manual number (part number) /ECN (date code). Generally, when a replacement manual is furnished, it will have the same published manual number, but the latest available ECN. This provides the user with the latest information applicable to his machine. Similarly all documents comprising the manual will be the latest available as of the date the manual was printed, **even though older ECN dates for those documents may be listed in the table of contents.**

When communicating with the Milnor factory regarding this manual, please also provide the other identifying information shown on the cover, including the publishing system, access date, and whether the document ECN's are the latest available or exact.

References to Yellow Troubleshooting Pages

This manual may contain references to "yellow pages." Although the pages containing troubleshooting procedures are no longer printed on yellow paper, troubleshooting instructions, if any, will be contained in the easily located "Troubleshooting" chapter or section. See the table of contents.

Trademarks of Pellerin Milnor Corporation

The following, some of which may be used in this manual, are trademarks of Pellerin Milnor Corporation:

Ampsaver [®]	Dye-Extractor [®]	Gear Guardian [®]	Milnet [®]	Staph-Guard [®]
Autolint [®]	Dyextractor [®]	Hands-Off [®]	Milnor [®]	System 4 [®]
Auto-Purge [®]	E-P Express [®]	Hydro-Cushion [®]	Miltrac	System 7 [®]
Autovac	E-P OneTouch [®]	Mildata [®]	Miltron	Totaltrol [®]
CBW [®]	E-P Plus [®]			

Comments and Suggestions

Help us to improve this manual by sending your comments to:

Pellerin Milnor Corporation
Attn: Technical Publications
P. O. Box 400
Kenner, LA 70063-0400

Fax: (504) 469-1849

INSTRUCTIONS FOR K 15-0008 KIT

NOTE: At the bottom end of each Hydro Cushion is a "timing" washer, which is held fast with one stud to prevent the unit from rotating. You will find it easier to remove this stud so the complete unit can be rotated to put the head bolts in the most accessible position. Return the unit to its original position and replace stud, when finished, to prevent it from turning while machine is operating.

STEP 1: Clean Hydro Cushion head (top) and stem to remove excess oil and lint.

STEP 2: Install "split" seals, one at a time, around stem and push down into recessed hole in plastic bushing. Install seals with lip pointing down and stagger split joints.

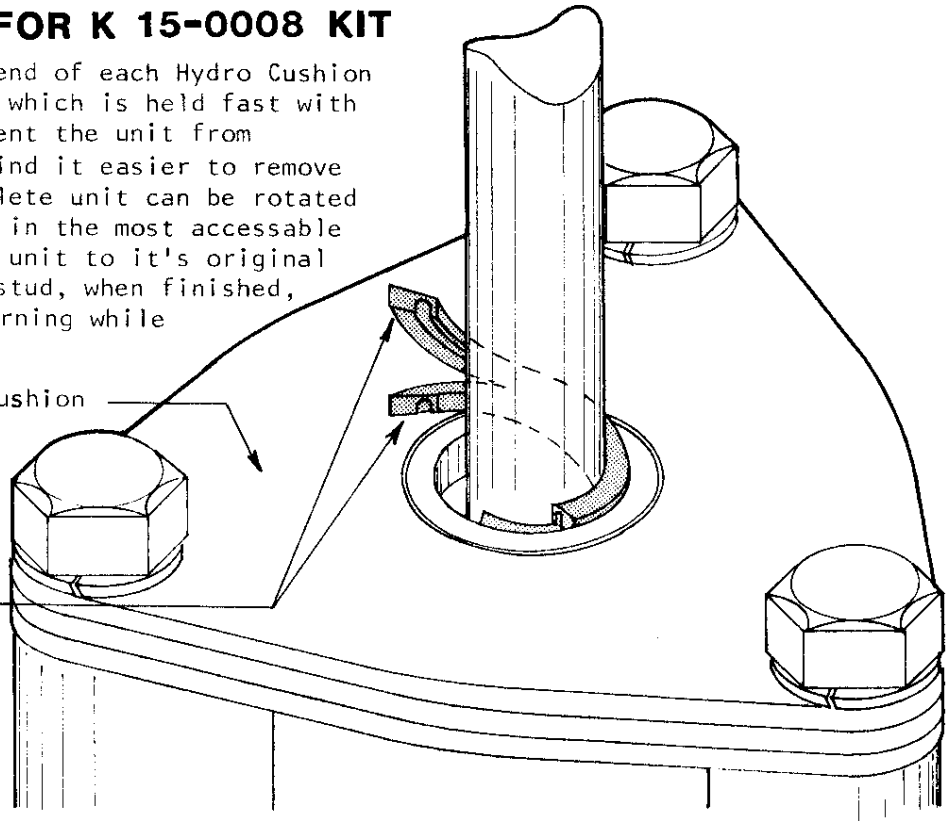

STEP 3: Loosen, but do not remove, one of the bolts holding the cylinder head.

STEP 4: Slip the slotted hole end of seal retainer under the bolt head and washer. Move retainer into position with other end over seals. Be sure to hold seal retainer 1/8" away from piston rod, as shown.

STEP 5: Repeat steps 3 and 4 for each of the other two cylinder head bolts.

CAUTION: Never loosen more than one cylinder head bolt at a time because end plates are under heavy spring pressure.

